

VALKO[®]
SINCE 1995

Idrochef

Cottura
precisa,
**stile
assoluto.**

*Precise cooking,
absolute style.*



Idrochef

Codice Code	Modello Model
1410V350	Idrochef 216 Touch
1410V351	Idrochef 316 Touch



Altezza min. vasca 200 mm
Min. height of the tank 200 mm
Hauteur min. récipient 200 mm
Mindesthöhe des Behälters 200 mm
Altura min. del contenedor 200 mm



Capacità 60 L (216), 70 L (316)
Capacity 60 L (216), 70 L (316)
Capacité 60 L (216), 70 L (316)
Kapazität 60 L (216), 70 L (316)
Capacidad 60 L (216), 70 L (316)



Capacità carico di cottura 18 Kg (216), 25 Kg (316)
Cooking load capacity 18 Kg (216), 25 Kg (316)
Capacité de chargement de cuisson 18 Kg (216), 25 Kg (316)
Kapazität des Garvolumens 18 Kg (216), 25 Kg (316)
Capacidad de cocción 18 Kg (216), 25 Kg (316)

Apparecchio per cottura sottovuoto

Sous vide immersion cooker
Équipement pour la cuisson sous vide
Sous Vide-Garer
Aparato para la cocción al vacío

Caratteristiche e vantaggi

- Con nuovo touch screen da 2,8"
- Con 4 categorie di prodotti - 10 ricette per ogni categoria
- Circolazione orizzontale dell'acqua
- Sensore della temperatura ad alta precisione 1/10°C
- Preriscaldamento programmato
- Modalità manuale per un uso più esperto
- Wi-Fi

Characteristics and advantages

- With new 2.8" touch screen
- With 4 product categories - 10 recipes for each category
- Horizontal water circulation
- High-precision temperature sensor 1/10°C
- Programmed preheating
- Manual mode for advanced use
- Wi-Fi

Caractéristiques et avantages

- Avec nouvel écran tactile de 2,8 pouces
- Avec 4 catégories de produits - 10 recettes pour chaque catégorie
- Circulation horizontale de l'eau
- Capteur de température haute précision 1/10°C
- Préchauffage programmé
- Mode manuel pour une utilisation avancée
- Wi-Fi

Merkmale und Vorteile

- Mit neuem 2,8 Touchscreen
- Mit 4 Produktkategorien - 10 Rezepte für jede Kategorie
- Horizontaler Wasserzirkulation
- Hochpräziser Temperatursensor 1/10°C
- Programmierbare Vorheizfunktion
- Manueller Modus für erfahrene Anwender
- Wi-Fi

Características y ventajas

- Con una nueva pantalla táctil de 2,8"
- Con 4 categorías de productos - 10 recetas para cada categoría
- Circulación de agua horizontal
- Sensor de temperatura de alta precisión 1/10°C
- Precaentamiento programado
- Modo manual para un uso más avanzado
- Wi-Fi

Il nuovo touch screen

The new touch screen
Le nouvel écran tactile
Der neue Touchscreen
La nueva pantalla táctil



01 Cottura professionale manuale

02 Preriscaldamento programmato

03 Pulizia

04 Ricette

1. Manual professional cooking
2. Timed preheating
3. Cleaning
4. Recipes

1. Cuisson professionnelle manuelle
2. Préchauffage programmé
3. Nettoyage
4. Recettes

1. Manuelles professionnelles Garen
2. Programmiertes Vorheizen
3. Reinigung
4. Rezepte

1. Cocción profesional manual
2. Pre calentamiento programado
3. Limpieza
4. Recetas

La cottura delicata a bassa temperatura

- Esaltazione dei sapori
- Minor calo peso
- Migliore organizzazione dello stoccaggio
- Gestione dei cali e dei picchi di lavoro

Gentle cooking at low temperature

- Brings out flavours
- Lower food mass loss
- Better storage organization
- Better management of workload peaks and troughs

La cuisson délicate à basse température

- Exaltation des saveurs
- Moins de perte de poids
- Meilleure organisation du stockage
- Gestion des baisses et pics de travail

Schonendes Garen bei niedriger Temperatur

- Verstärkung der Aromen
- Weniger Gewichtsverlust
- Bessere Organisation der Lebensmittel-Lagerung
- Effizientes Lebensmittelmanagement bei hoher und niedriger Nachfrage

La cocción suave a baja temperatura

- Exaltación de los sabores
- Menor pérdida de peso
- Mejor organización del almacenamiento
- Gestión de bajadas y picos de trabajo



Accessori

Optionals
Accessoires
Zubehör
Accesorios

Scheda tecnica e caratteristiche

Technical details and features
Fiche technique et caractéristiques
Technische Details und Merkmale
Detalles técnicos y características



Bacinella Gastronorm PC

Gastronorm tray
Bac Gastronorm
Gastronorm Behälter
Contenedor Gastronorm

10040062 - GN1/1
10040074 - GN2/1



Bacinella Gastronorm inox

Gastronorm tray
Bac Gastronorm
Gastronorm Behälter
Contenedor Gastronorm

10040061 - GN1/1
10040073 - GN2/1

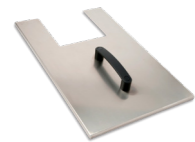

Coperchio inox per bacinella Gastronorm

Inox lid for Gastronorm
Couvercle inox pour bac Gastronorm
Edelstahl Deckel für Gastronorm Behälter
Tapa inox para contenedor Gastronorm

1408V079 - GN1/1
1408V100 - GN2/1



Coperchio isolante per bacinella Gastronorm

Insulating lid for Gastronorm tray
Couvercle isolant pour bac Gastronorm
Isolierender Deckel für Gastronorm Behälter
Tapa aislante para contenedor Gastronorm

1408V123 - GN1/1
1408V124 - GN2/1



Divisorio per bacinella

Dividing grid for tray
Grille de séparation pour bac
Trenngitter für Garbehälter
Divisorio para contenedor

0401VB25



Sonda al cuore con ago, termocoppia T

Core probe needle, T type thermocouple
Aiguille de la sonde au coeur, thermocouple de type T
Kerntemperaturfühler mit Nadel, T-Thermolement
Sonda al corazón con aguja, termopar tipo T

09040017



Salvataggio dati su Cloud, canone annuo

Cloud Storage, annual fee
Sauvegarde des données sur le Cloud,
cotisation annuelle
Cloud Datenspeicher, Jahresgebühr
Almacenamiento de datos en el Cloud, cuota anual

000CLOUD



Eko Cleaner, anticalcare e disincrostante (6 flaconi x 1 L)

Eko Cleaner, descaler and degreaser (6 x 1 L)
Eko Cleaner, détartrage et décroûillage (6 x 1L)
Eko Cleaner, Entkalker und Entkruster (6 x 1L)
Eko Cleaner, desincrustante y desengrasante (6 x 1 L)

15030125



Vasca per la cottura sottovuoto con coperchio

Cooking tray with lid for vacuum cooking
Cuve de cuisson avec couvercle
Sous Vide Garbehälter mit Deckel
Cuba de cocción con tapa

1410V301 - Idrochef 316 Touch

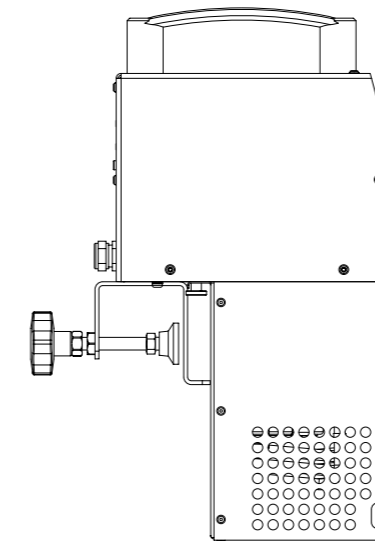

PROFONDITÀ DEPTH PROFONDEUR TIEFE PROFUNDIDAD

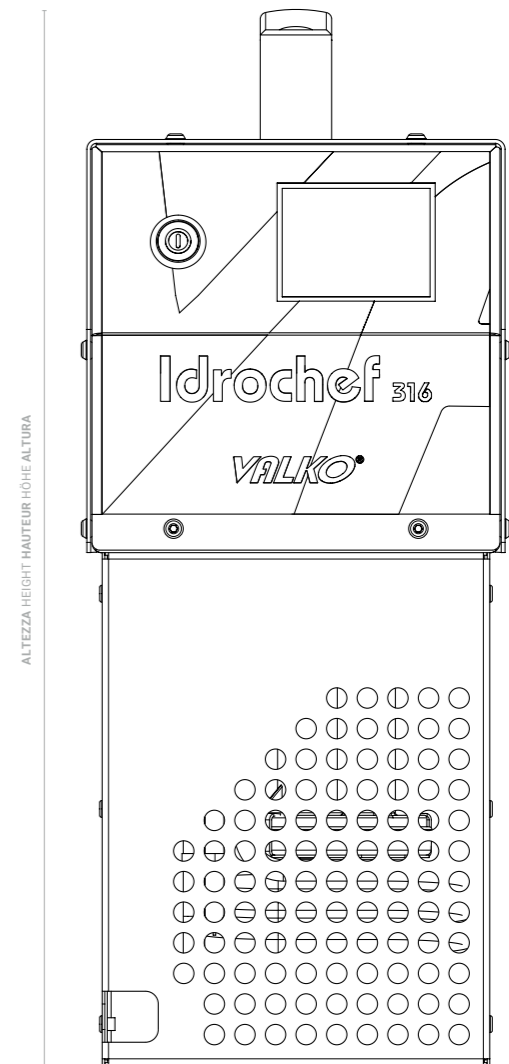
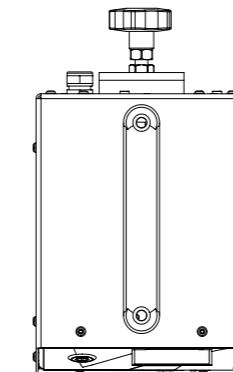

ALTEZZA HEIGHT HAUTEUR HÖHE ALTURA

LARGHEZZA WIDTH LARGEUR BREITE ANCHURA

Modello Model Modèle Modell Modelo	Larghezza Width Largeur Breite Anchura	Profondità Depth Profondeur Tiefe Profundidad	Altezza Height Hauteur Höhe Altura	Temperatura di lavoro Working temperature range Température de travail Temperaturbereich Rango de temperatura de trabajo	Tensione Voltage Tension Spannung Voltaje	Potenza Power Puissance Leistung Potencia	Peso Weight Poids Gewicht Peso
Idrochef 216 Touch	164 mm	220 mm	415 mm	≤ 95°C	230V~	2000 W	8 Kg
Idrochef 316 Touch	164 mm	220 mm	415 mm	≤ 95°C	230V~	3000 W	8 Kg



Via Berlino, 1 - 24040 Bottanuco
Bergamo, Italy

tel +39.035.4992010
fax +39.035.4992015

info@valko.com
www.valko.com

VALKO is a registered trademark owned by CB srl